

PLANTA GERAL  
1:75



**PREFEITURA MUNICIPAL DE SÃO MATEUS**  
ADM 2021/2024  
SECRETARIA MUNICIPAL DE ASSISTENCIA SOCIAL

TÍTULO: **REMANESCENTE DA REFORMA DO CENTRO DE REFERENCIA DE ASSISTENCIA SOCIAL - CREAS**

LOCAL: **ASSISTENCIA SOCIAL - CREAS**

PROPRIETÁRIO: **MUNICIPIO DE SÃO MATEUS, ESTADO DO ESPIRITO SANTO**      RESP.TÉCNICO: **MUNICIPIO DE SÃO MATEUS, ESTADO DO ESPIRITO SANTO**

CONTEÚDO: **PLANTA BAIXA, REFORMA E AFINS**      DATA: **00**      REVISÃO: **00**      FOLHA: **1 / 10**      ESCALA: **INDICADAS**

PORTAS				
ID	Quantid...	L x H	Abertura	Material
P-01	2	0,60x2,10	NORMAL	MADEIRA
P-02	1	0,60x2,10	NORMAL	ALUMINIO VENEZIANO
P-03	1	0,70x2,10	NORMAL	MADEIRA
P-04	8	0,80x2,10	NORMAL	MADEIRA
P-05	1	0,90x2,10	NORMAL	MADEIRA

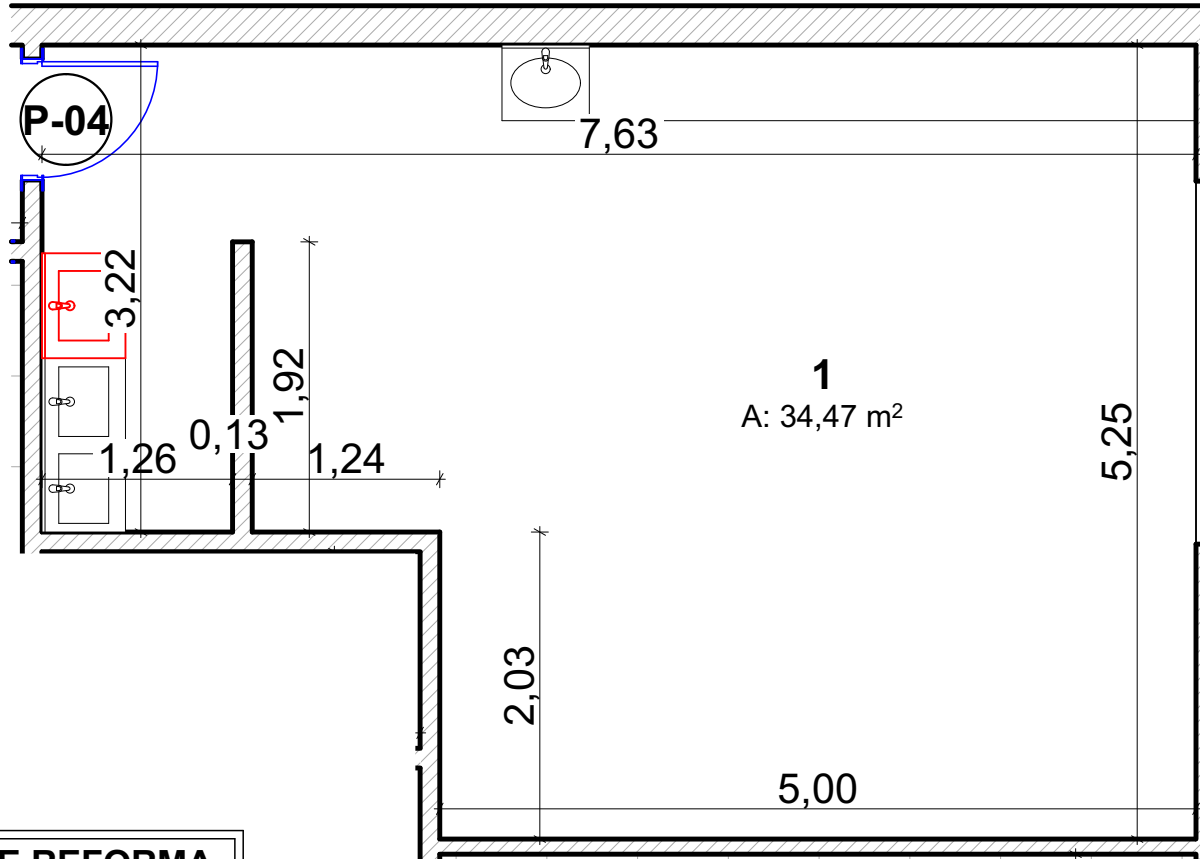

**BANCADA À SER  
RETIRADA 60x60  
cm**

**METRAGEM  
LINEAR  
APROXIMADA:  
27,57 m**

**OBS:  
LIXAMENTO E  
PINTURA DE  
TODAS AS  
PAREDES**

**DETALHE 01  
1:50**

LEGENDA DE REFORMA	
	EXISTENTE
	À DEMOLIR
	À CONSTRUIR



**PREFEITURA MUNICIPAL DE SÃO MATEUS**  
ADM 2021/2024  
SECRETARIA MUNICIPAL DE ASSISTENCIA SOCIAL

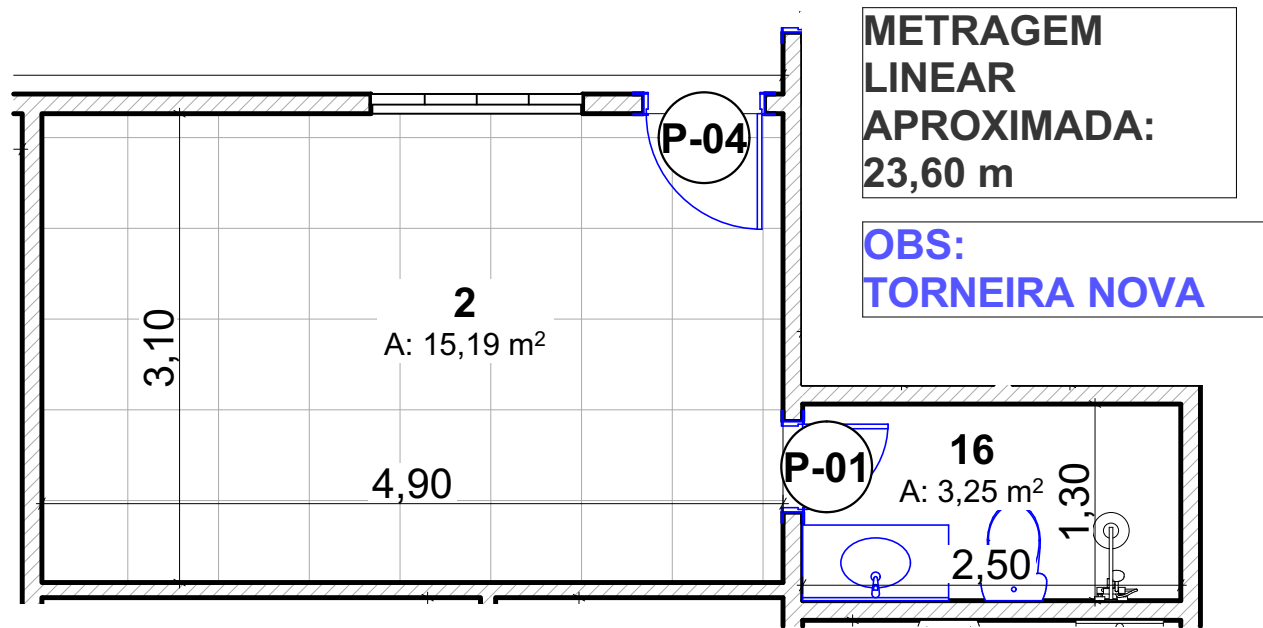

LOCAL: ASSISTENCIA SOCIAL-CREAS	
RESP. TÉCNICO ENG.CIVIL:  ENGENHEIRO CIVIL - CREA - (CARIMBO)	DESENHO: ARTHUR ESTEVES COSTA
REVISÃO: 00	FOLHA: 2 / 10
TÍTULO: REMANESCENTE DA REFORMA DO CENTRO DE REFERENCIA DE ASSISTENCIA SOCIAL - CREAS	CONTEUDO: DETALHE 1
DATA: 22/04/2024	ESCALA: INDICADAS



**METRAGEM LINEAR APROXIMADA: 23,60 m**

**OBS: TORNEIRA NOVA**

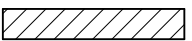
**DETALHE 02  
1:50**

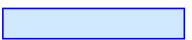
<b>LEGENDA DE REFORMA</b>	
	EXISTENTE
	À DEMOLIR
	À CONSTRUIR

**OBS: LIXAMENTO E PINTURA DE TODAS AS PAREDES**

 <p><b>PREFEITURA MUNICIPAL DE SÃO MATEUS</b> ADM 2021/2024 SECRETARIA MUNICIPAL DE ASSISTENCIA SOCIAL</p>	LOCAL: ASSISTENCIA SOCIAL-CREAS				
	RESP. TÉCNICO ENG.CIVIL: <hr/> ENGENHEIRO CIVIL - CREA - (CARIMBO)	DESENHO: ARTHUR ESTEVES COSTA			
TÍTULO: REMANESCENTE DA REFORMA DO CENTRO DE REFERENCIA DE ASSISTENCIA SOCIAL - CREAS	CONTEUDO: DETALHE 2	DATA: 22/04/2024	REVISÃO: 00	FOLHA: 3 / 10	ESCALA: INDICADAS

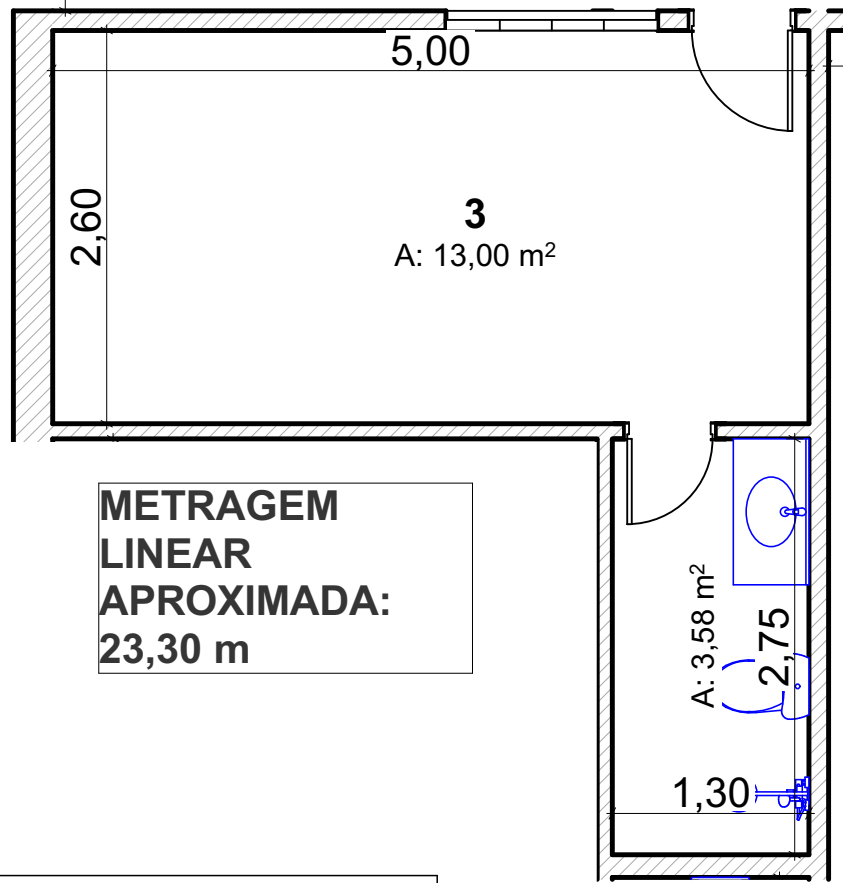

**METRAGEM LINEAR APROXIMADA: 23,30 m**

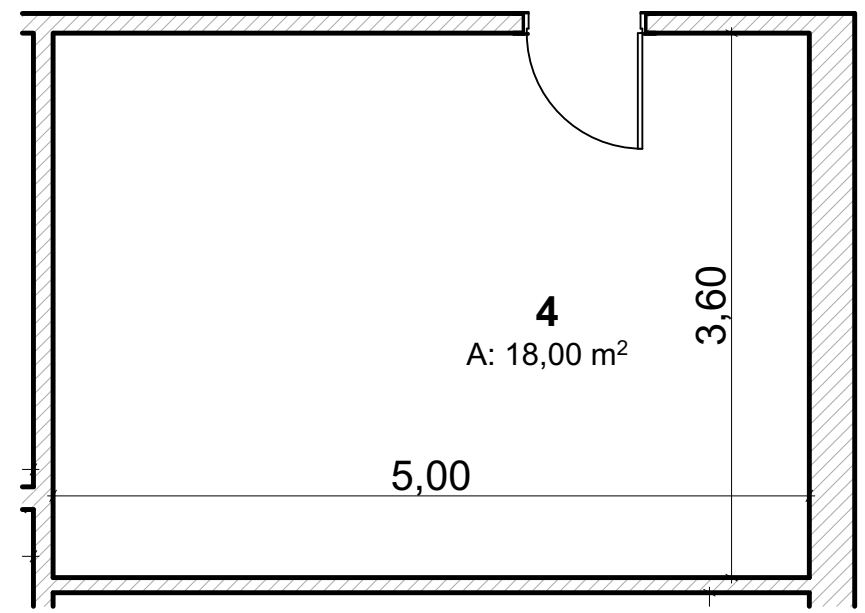

**DETALHE 03**  
1:50



**DETALHE 04**  
1:50

**OBS: TROCA DE TODO FORRO PVC**  
**METRAGEM LINEAR APROXIMADA: 17,20 m**

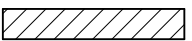
**OBS: LIXAMENTO E PINTURA DE TODAS AS PAREDES**

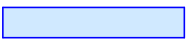
LEGENDA DE REFORMA	
	EXISTENTE
	À DEMOLIR
	À CONSTRUIR



**PREFEITURA MUNICIPAL DE SÃO MATEUS**  
ADM 2021/2024  
SECRETARIA MUNICIPAL DE ASSISTENCIA SOCIAL

TITULO:	REMANESCENTE DA REFORMA DO CENTRO DE REFERENCIA DE ASSISTENCIA SOCIAL - CREAS
CONTEUDO:	DETALHE 3,4
DATA:	22/04/2024

LOCAL: ASSISTENCIA SOCIAL-CREAS	
RESP. TÉCNICO ENG.CIVIL:  ENGENHEIRO CIVIL - CREA - (CARIMBO)	DESENHO: ARTHUR ESTEVES COSTA
REVISÃO: 00	FOLHA: 4 / 10
ESCALA: INDICADAS	

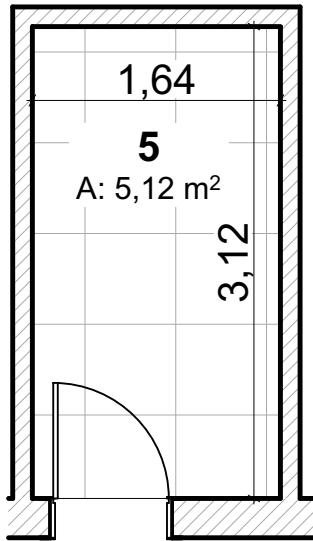

**DETALHE 05**

1:50

**METRAGEM LINEAR APROXIMADA: 9,52 m**

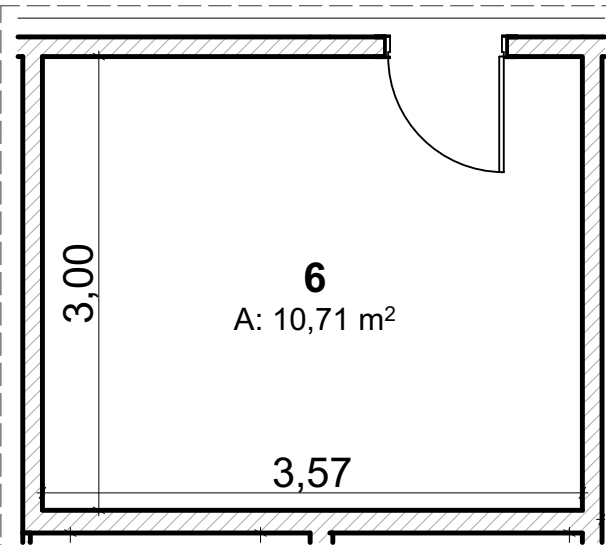

**DETALHE 06**

1:50

**OBS: TROCA DE TODO FORRO PVC**  
**METRAGEM LINEAR APROXIMADA: 13,14 m**

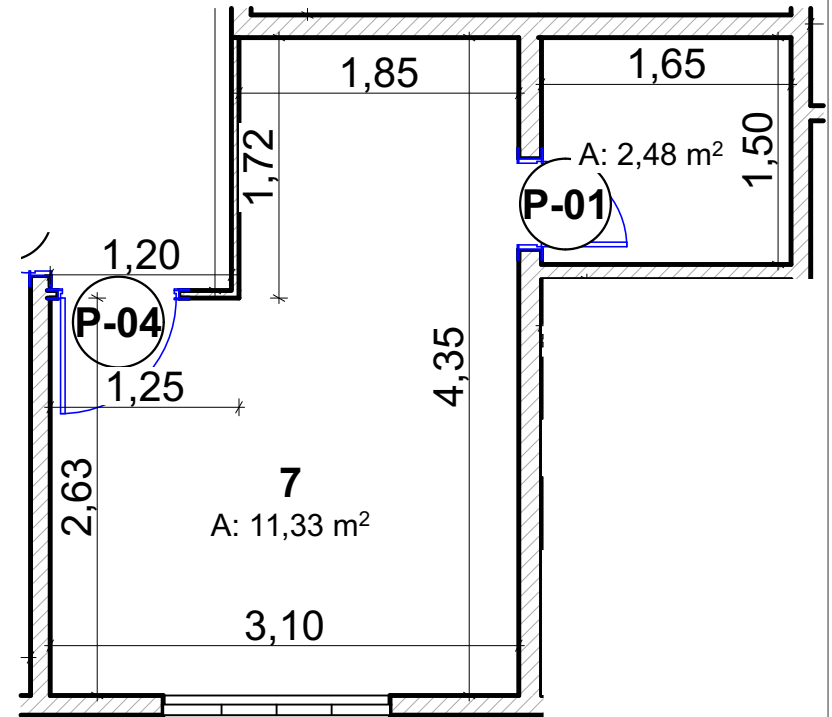

**DETALHE 07**

1:50

**METRAGEM LINEAR APROXIMADA: 21,20 m**

**LEGENDA DE REFORMA**

	EXISTENTE
	À DEMOLIR
	À CONSTRUIR

**OBS: LIXAMENTO E PINTURA DE TODAS AS PAREDES**



**PREFEITURA MUNICIPAL DE SÃO MATEUS**  
ADM 2021/2024  
SECRETARIA MUNICIPAL DE ASSISTENCIA SOCIAL

LOCAL: ASSISTENCIA SOCIAL-CREAS

RESP. TÉCNICO ENG.CIVIL:

ENGENHEIRO CIVIL - CREA - (CARIMBO)

DESENHO:

ARTHUR ESTEVES COSTA

TÍTULO:

REMANESCENTE DA REFORMA DO CENTRO DE REFERENCIA DE ASSISTENCIA SOCIAL - CREAS

CONTEUDO:

DETALHE 5,6,7

DATA:

22/04/2024

REVISÃO:

00

FOLHA:

5 / 10

ESCALA:

INDICADAS

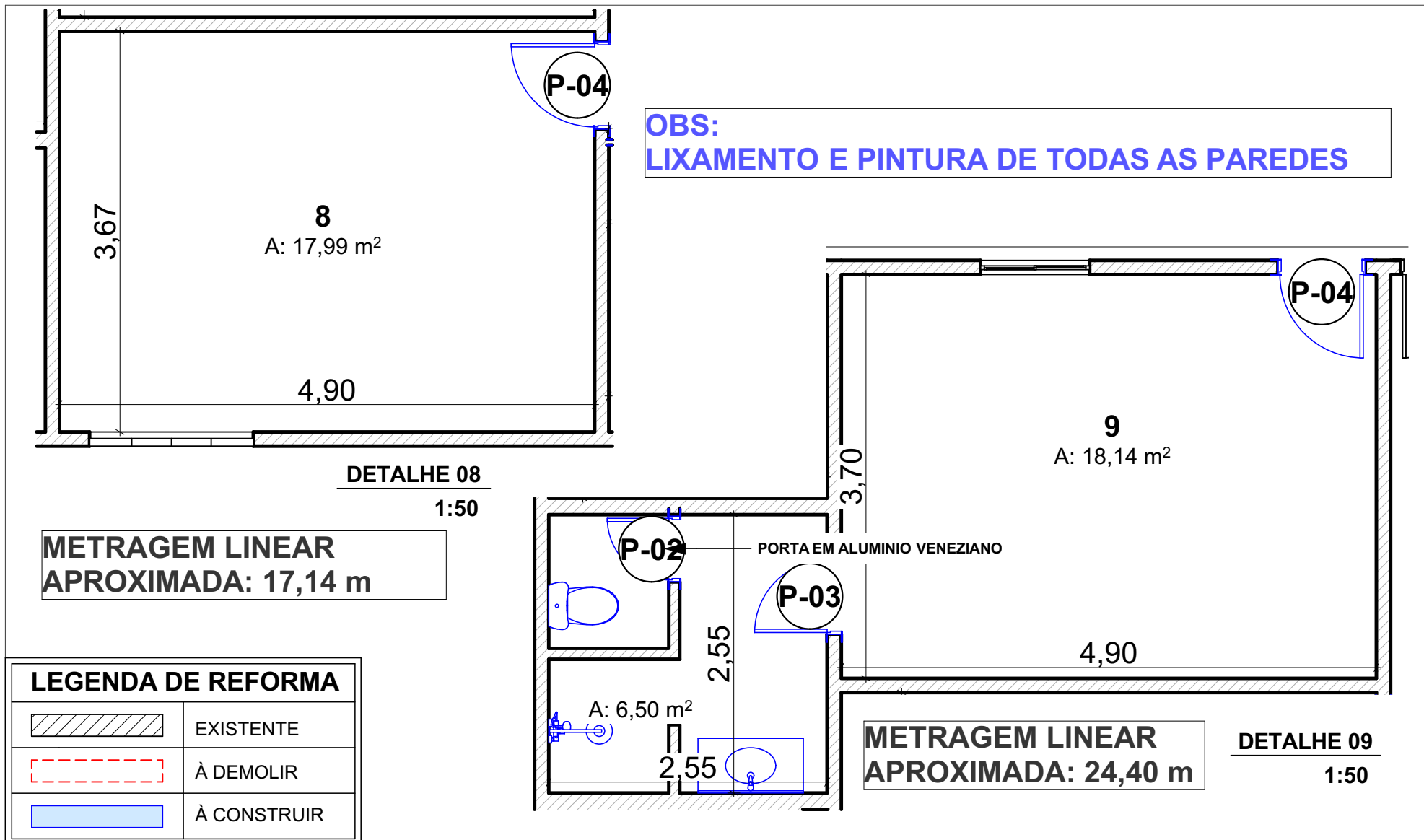

**PREFEITURA MUNICIPAL DE SÃO MATEUS**  
ADM 2021/2024  
SECRETARIA MUNICIPAL DE ASSISTENCIA SOCIAL

LOCAL: ASSISTENCIA SOCIAL-CREAS

RESP. TÉCNICO ENG.CIVIL:

ENGENHEIRO CIVIL - CREA - (CARIMBO)

DESENHO:

ARTHUR ESTEVES COSTA

TÍTULO:

REMANESCENTE DA REFORMA DO CENTRO DE REFERENCIA DE ASSISTENCIA SOCIAL - CREAS

CONTEUDO:

DETALHE 8,9

DATA:

22/04/2024

REVISÃO:

00

FOLHA:

6 / 10

ESCALA:

INDICADAS

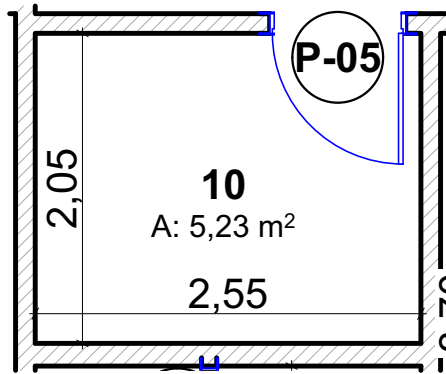

**DETALHE 10**  
1:50

**METRAGEM LINEAR APROXIMADA:**  
9,20 m

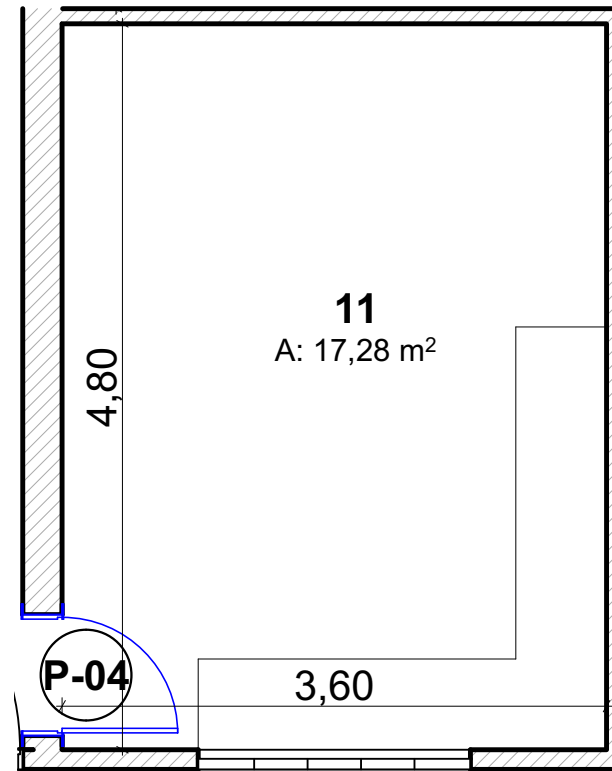

**DETALHE 11**  
1:50

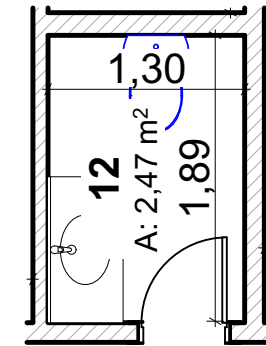



**DETALHE 12**  
1:50

**METRAGEM LINEAR APROXIMADA:**  
6,38 m

**METRAGEM LINEAR APROXIMADA: 16,80 m**

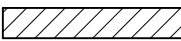
**OBS:**  
**LIXAMENTO E PINTURA DE TODAS AS PAREDES**

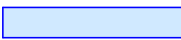
LEGENDA DE REFORMA	
	EXISTENTE
	À DEMOLIR
	À CONSTRUIR



**PREFEITURA MUNICIPAL DE SÃO MATEUS**  
ADM 2021/2024  
SECRETARIA MUNICIPAL DE ASSISTENCIA SOCIAL

LOCAL: ASSISTENCIA SOCIAL-CREAS

RESP. TÉCNICO ENG.CIVIL:

ENGENHEIRO CIVIL - CREA - (CARIMBO)

DESENHO:

ARTHUR ESTEVES COSTA

TÍTULO:

REMANESCENTE DA REFORMA DO CENTRO DE REFERENCIA DE ASSISTENCIA SOCIAL - CREAS

CONTEUDO:

DETALHE 10,11,12

DATA:

22/04/2024

REVISÃO:

00

FOLHA:

7 / 10

ESCALA:

INDICADAS

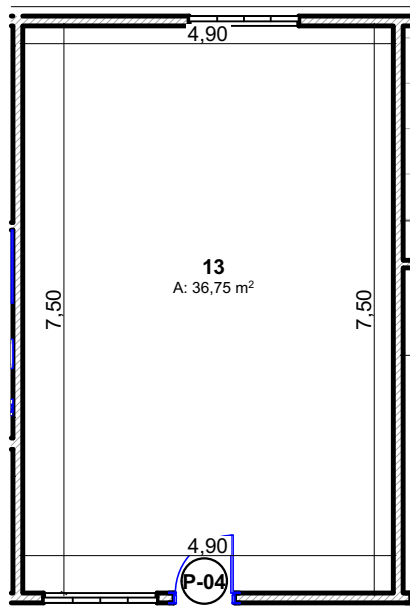

**DETALHE 13**

1:100

**METRAGEM LINEAR  
APROXIMADA: 24,80 m**

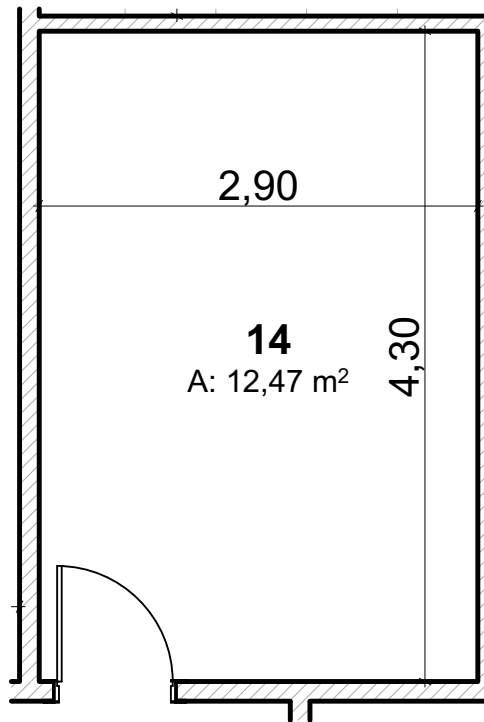

**DETALHE 14**

1:50

**METRAGEM LINEAR  
APROXIMADA: 14,40 m**

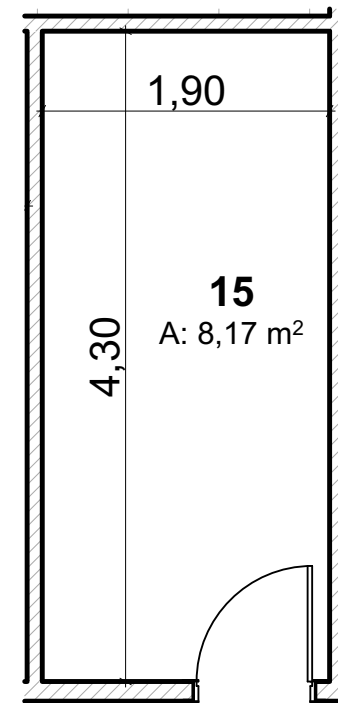



**DETALHE 15**

1:50

**METRAGEM LINEAR  
APROXIMADA: 6,20 m**

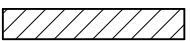
**LEGENDA DE REFORMA**

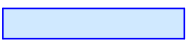
	EXISTENTE
	À DEMOLIR
	À CONSTRUIR

**OBS:  
LIXAMENTO E PINTURA DE TODAS AS PAREDES**



**PREFEITURA MUNICIPAL DE SÃO MATEUS**  
ADM 2021/2024  
SECRETARIA MUNICIPAL DE ASSISTENCIA SOCIAL

LOCAL: ASSISTENCIA SOCIAL-CREAS

RESP. TÉCNICO ENG.CIVIL:

ENGENHEIRO CIVIL - CREA - (CARIMBO)

DESENHO:

ARTHUR ESTEVES COSTA

TÍTULO:

REMANESCENTE DA REFORMA DO CENTRO DE REFERENCIA DE ASSISTENCIA SOCIAL - CREAS

CONTEUDO:

DETALHE 13,14,15

DATA:

22/04/2024

REVISÃO:

00

FOLHA:

8 / 10

ESCALA:

INDICADAS



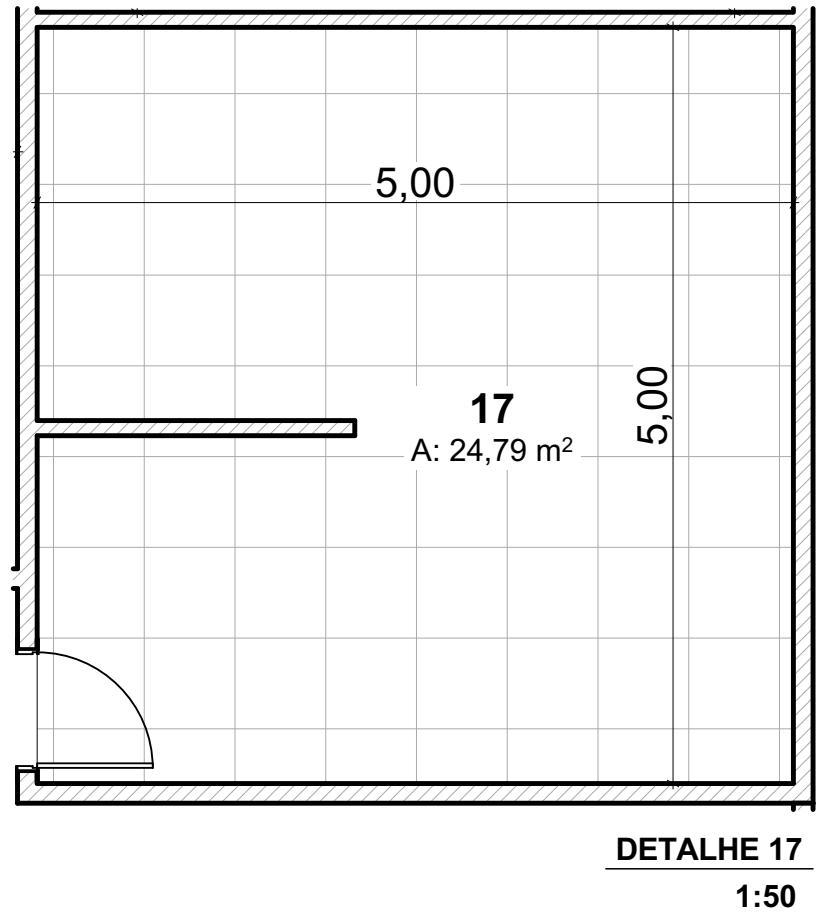
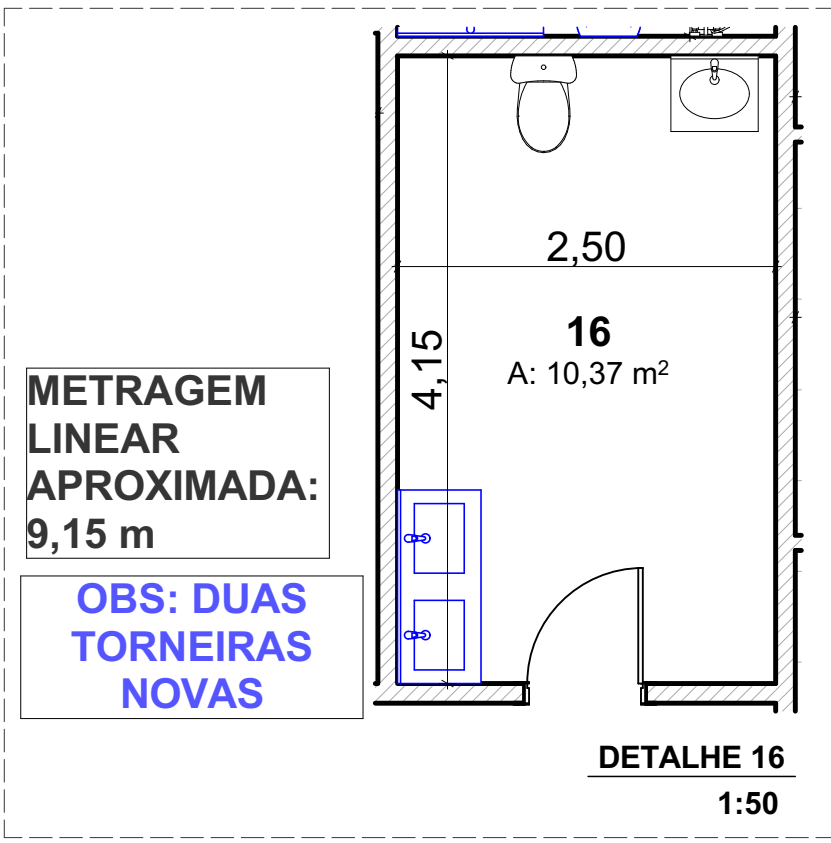

**LEGENDA DE REFORMA**

	EXISTENTE
	À DEMOLIR
	À CONSTRUIR

**OBS: LIXAMENTO E PINTURA DE TODAS AS PAREDES**

<p><b>PREFEITURA MUNICIPAL DE SÃO MATEUS</b> ADM 2021/2024 SECRETARIA MUNICIPAL DE ASSISTENCIA SOCIAL</p>	LOCAL:	ASSISTENCIA SOCIAL-CREAS			
	RESP. TÉCNICO ENG.CIVIL:	 <small>ENGENHEIRO CIVIL - CREA - (CARIMBO)</small>		DESENHO:	ARTHUR ESTEVES COSTA
TITULO:	CONTEUDO:	DATA:	REVISÃO:	FOLHA:	ESCALA:
REMANESCENTE DA REFORMA DO CENTRO DE REFERENCIA DE ASSISTENCIA SOCIAL - CREAS	DETALHE 16,17	22/04/2024	00	9 / 10	INDICADAS

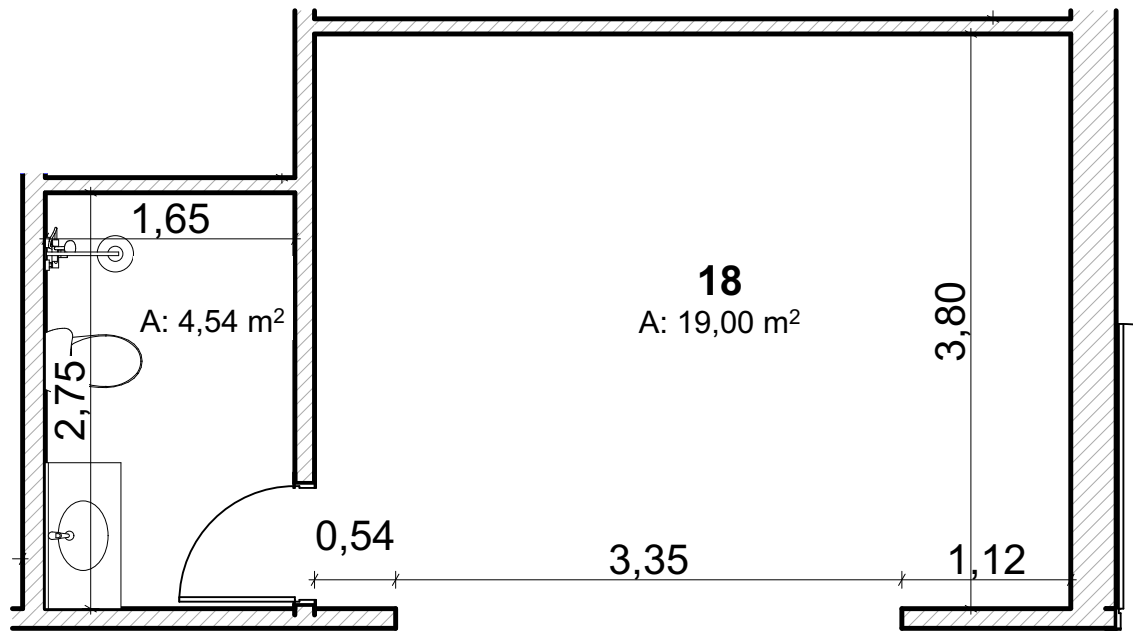

**DETALHE 18**

1:50

**METRAGEM LINEAR APROXIMADA: 26,40 m**



**SALA ADMINISTRATIVA**

1:50

**METRAGEM LINEAR APROXIMADA: 13,78 m**

**LEGENDA DE REFORMA**

	EXISTENTE
	À DEMOLIR
	À CONSTRUIR

**OBS:**  
**LIXAMENTO E PINTURA DE TODAS AS PAREDES**



**PREFEITURA MUNICIPAL DE SÃO MATEUS**  
ADM 2021/2024  
**SECRETARIA MUNICIPAL DE ASSISTENCIA SOCIAL**

LOCAL: ASSISTENCIA SOCIAL-CREAS

RESP. TÉCNICO ENG.CIVIL:  
\_\_\_\_\_  
ENGENHEIRO CIVIL - CREA - (CARIMBO)

DESENHO:  
ARTHUR ESTEVES COSTA

TITULO: REMANESCENTE DA REFORMA DO CENTRO DE REFERENCIA DE ASSISTENCIA SOCIAL - CREAS

CONTEUDO: DETALHE 18, SALA ADMINISTRATIVA

DATA: 22/04/2024

REVISÃO: 00

FOLHA: 10 / 10

ESCALA: INDICADAS